

NO	DESCRIPTION	MATERIAL	Q'TY	FINISH	REMARK
1	BODY 1	BRASS	1	NICKEL	B-SMA0065-N
2	INSULATION 1	TEFLON	1	TEFLON	I-0160T
3	BODY2	BRASS	1	NICKEL	B-BNC0361-N
4	WASHER	BRASS	1	BRASS	W-0025-N
5	SPRING	BRASS	1	NICKEL	W-0024-N
6	WASHER	BRASS	1	NICKEL	W-0026-N
7	GASKET	SI RUBBER	1	RUBBER	RU-0010
8	BODY 3	BRASS	1	NICKEL	B-TNC0083-N
9	INSULATION 2	TEFLON	1	TEFLON	I-0172T
10	PIN	PH.BRONZE	1	GOLD	P-SMA0274-G

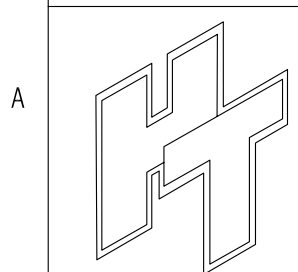
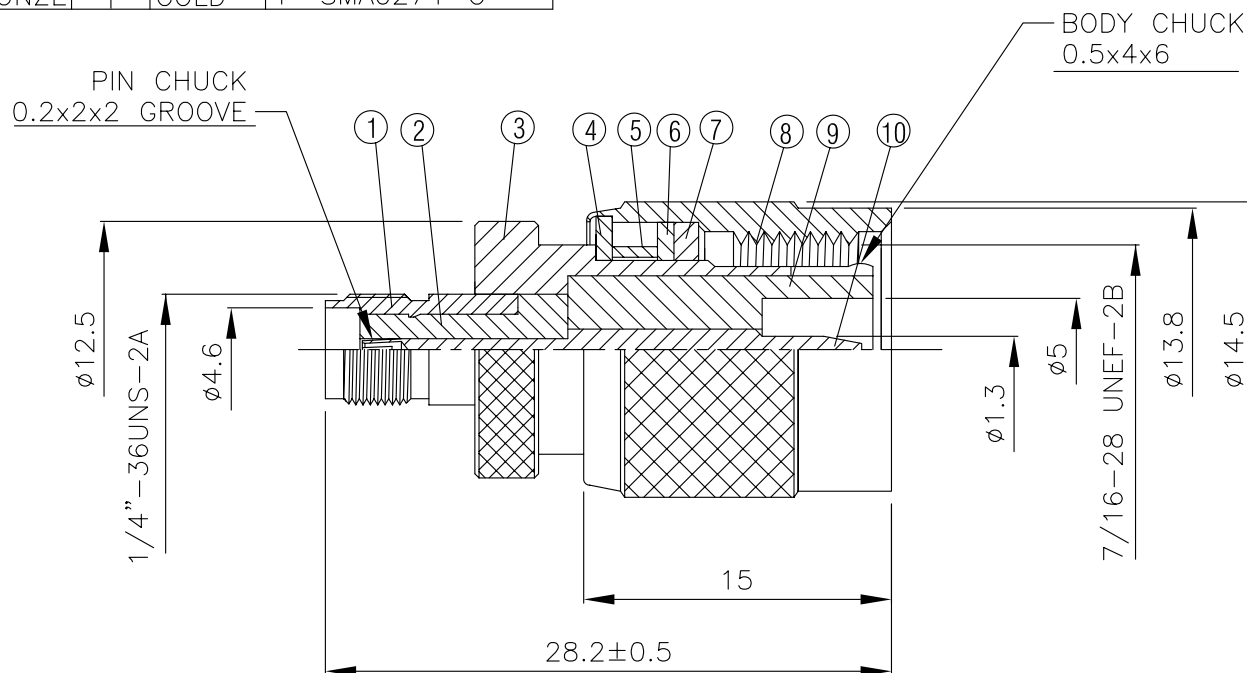
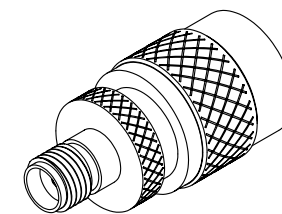

HUS-TSAN GROUP CO., LTD.
P.O.BOX 40-76.TAINAN.TAIWAN,R.O.C.
TITLE
SMA FEMALE-TNC MALE ADAPTOR
PART NO.
SMA-27-TGN
DRAWING NO.
SMA 27 TGN

DRAWN MARY
CHECKED 蘇志欣
Q.A. 蘇姿潔
APPROVAL 徐燦霖
REVISION

DATE 96.03.27
DATE 97.04.29
DATE
DATE
DATE

DIMENSIONS ARE IN MILLIMETERS
UNLESS OTHERWISE SPECIFIED TOLERANCE
0.5-5=±0.2 120-315=±1
5-30= ±0.4 315-1000=±1.6
30-120±0.6 1000-2000=±2.4
SCALE 4:1 **SIZE** A

REVISION	
DESCRIPTION	ENGINEER